

Superreel® - Industrial Reel

AESC370D SERIES



FEATURES

- To handle live electric cable/cord.
- Powered by electric motor. High Power.
- Silver alloy slip ring.
- Durable abrasion and corrosion resistant baked-on power coat finish.
- Rugged construction: Steel drum and all bolted construction. Vibration-proof self-locking fasteners.
- Low maintenance: Dual main bearings never need lubrication.
- Compact for critical space requirements.
- Shipped completely assembled, ready to install.



Superreel® - Industrial Reel

DIMENSIONS

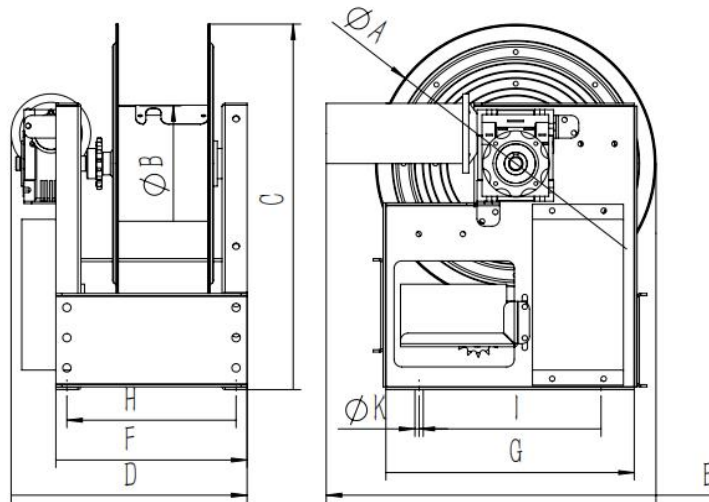

P/N	Port&core number	HOSE-ID. or CABLE-square	Pressure or lmax	Working length	Reel inlet	Cable outlet	A	B	C	D	E	F	G	H	I	J	K
AESC370D0405010020	4	1.5 ²	10A	30m	Bare wire	Bare wire	370	153	405	311	435	252	327	223	240	4	11
AESC370D0405010070	4	1.5 ²	10A	70m	Bare wire	Bare wire	370	153	405	411	435	352	327	323	240	4	11
AESC370D0406020020	4	2.5 ²	20A	20m	Bare wire	Bare wire	370	153	405	311	435	252	327	223	240	4	11
AESC370D0408030020	4	4 ²	30A	15m	Bare wire	Bare wire	370	153	405	311	435	252	327	223	240	4	11
AESC370D0409050020	4	6 ²	50A	10m	Bare wire	Bare wire	370	153	405	311	435	252	327	223	240	4	11

Dimensions are in millimeters

