

Superreel® - Industrial Reel

ASSH690D SERIES

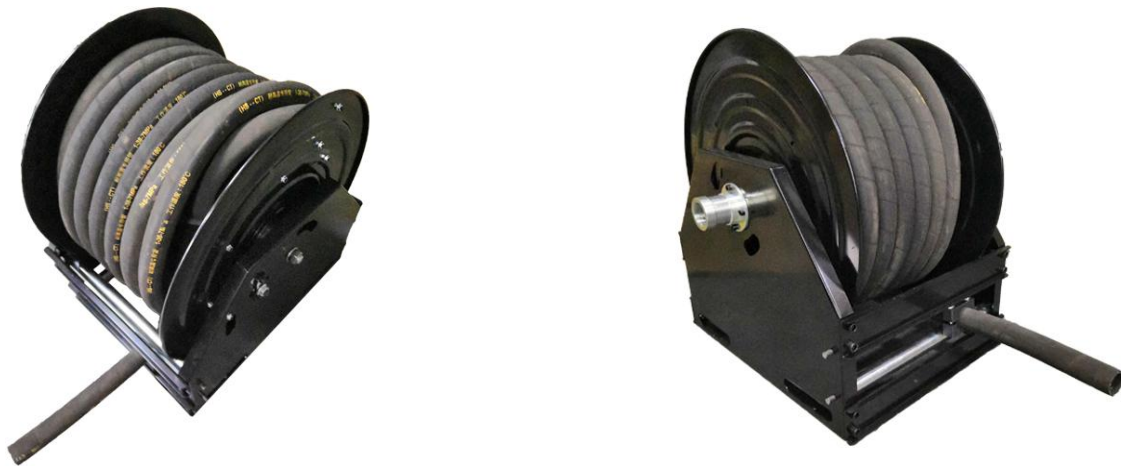

FEATURES

- Dual pedestal, heavy duty. Long-life design, all-steel construction and a baked-on power coat finish combine.
- Full flow shaft and swivel, high pressure.
- Reel drive springs manufactured from high-quality, scaleless blue tempered steel.
- Anti-lockout design: Ratchet prevents lockup when hose is fully extended, eliminating the need to manually release the pawl at the reel.
- Superior performance: Swivel and reel ball bearings reduce torque load on power spring for smooth retraction and durability.
- Corrosion resistant: Sealed bearings prevent contamination and minimize maintenance.
- Easy installation and maintenance: Factory lubricated one-piece power spring cassette make installation safer and maintenance easier.



WWW.SUPERREEL.COM

Email: sales@superreel.com

Superreel® - Industrial Reel

- Adjustable and Versatile: Guide arm adjust to wall, floor, vehicle, overhead positions.

DIMENSIONS

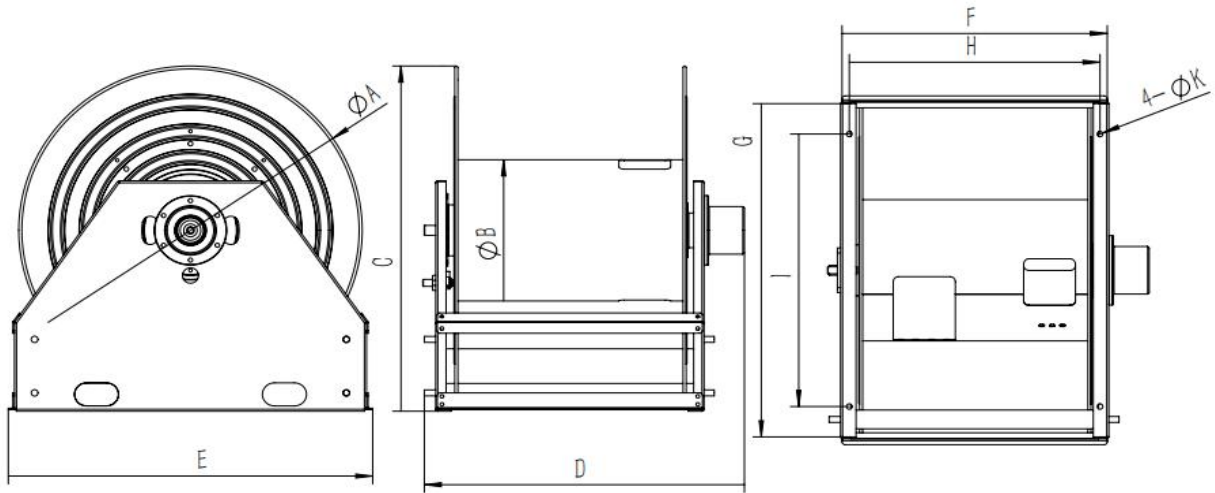

P/N	Port&core number	HOSE-ID. or CABLE-square	Pressure or lmax	Working length	Reel inlet	Hose outlet	A	B	C	D	E	F	G	H	I	J	K
ASSH690D0108160012	1	1-1/4"	16Mpa	12m	BSPT1-1/4".F	BSPT1-1/4".M	664	386	712	470	754	450	754	433	528	4	14
ASSH690D0109160010	1	1-1/2"	16Mpa	10m	BSPT1-1/2".F	BSPT1-1/2".M	664	386	712	470	754	450	754	433	528	4	14
ASSH690D0110160015	1	2"	1.6Mpa	15m	BSPT2".F	BSPT2".M	664	285	712	630	754	512	754	485	550	4	14
ASSH690D10160015 finished standard with small bend radius of hose.							Dimensions are in millimeters										

