

Superreel® - Industrial Reel

ESSC410F SERIES



FEATURES

- To handle live electric cable/cord.
- Professional grade heavy duty steel construction.
- Silver alloy slip ring.
- Available in Left or Right version
- Fixation by mounting flangel
- Self winding by permanent spring force
- Reel drive springs manufactured from high-quality, scaleless blue tempered steel.
- Durable abrasion and corrosion resistant baked-on power coat finish.
- Adjustable bumper stop allow any desired length of cord or cable to be maintained outside the reel.
- Compact for critical space requirements.



Superreel® - Industrial Reel

DIMENSIONS

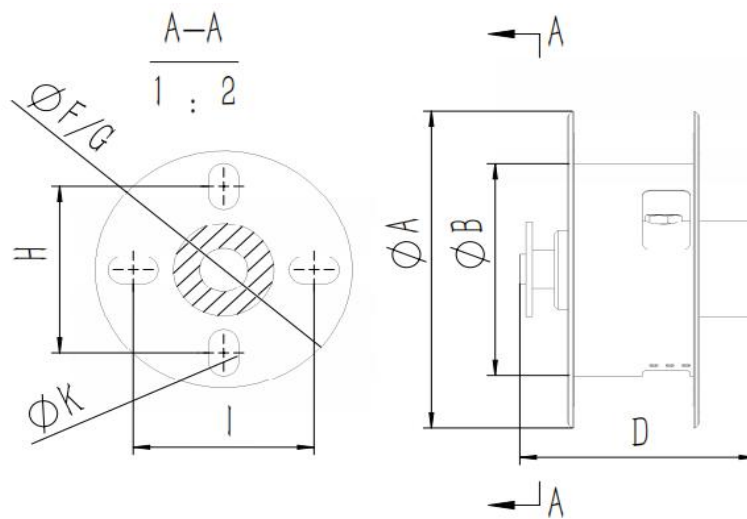

P/N	Port&core number	HOSE-ID. or CABLE-square	Pressure or lmax	Working length	Reel inlet	Cable outlet	A	B	C	D	E	F	G	H	I	J	K
ESSC410F0405010015	4	1.5 ²	10A	15m	Bare wire	Bare wire	410	270	410	275	410	128	128	90	90	4	14
ESSC410F0406020015	4	2.5 ²	20A	15m	Bare wire	Bare wire	410	270	410	275	410	128	128	90	90	4	14
ESSC410F0408030015	4	4 ²	30A	15m	Bare wire	Bare wire	410	270	410	275	410	128	128	90	90	4	14
ESSC410F0409050015	4	6 ²	50A	15m	Bare wire	Bare wire	410	270	410	275	410	128	128	90	90	4	14
ESSC410F2005010015	20	1.5 ²	10A	15m	Bare wire	Bare wire	410	270	410	275	410	128	128	90	90	4	14
							Dimensions are in millimeters										

