

Superreel® - Industrial Reel

ESDH370F SERIES



FEATURES

- Heavy duty. All-steel construction.
- For thermoplastic welded double hose with bigger diameter and bigger floating rate
- Available in Left or Right version
- Fixation by mounting flangel
- Self winding by permanent spring force
- Full flow shaft swivels.

1



WWW.SUPERREEL.COM

Email: sales@superreel.com

Superreel® - Industrial Reel

DIMENSIONS

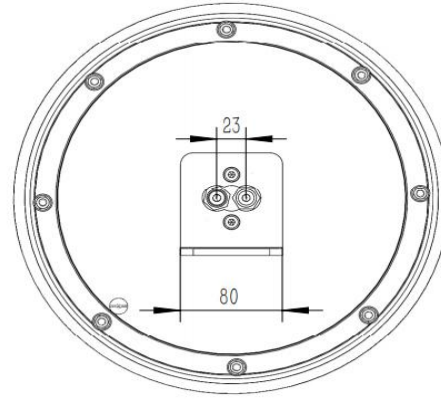
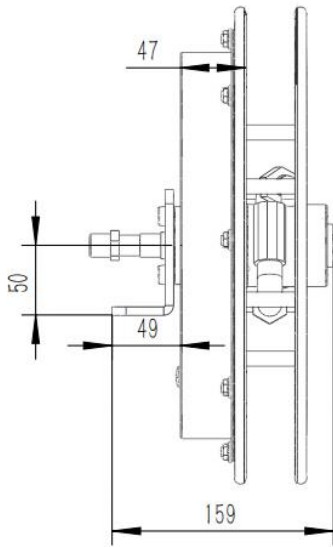

P/N	Port&core number	HOSE-ID. or CABLE-square	Pressure or lmax	Working Length	Reel inlet	Hose outlet	A	B	C	D	E	F	G	H	I	J	K
ESDH370F0201220006	2	1/4"	22MPA	6m	M16*1.5.M	M16*1.5.F	375	182	375	159	375	49	80	0	55	2	11
ESDH370F0202220005	2	5/16"	22MPA	5m	M16*1.5.M	M16*1.5.F	375	182	375	159	375	49	80	0	55	2	11
ESDH370F0203220004	2	3/8"	22MPA	4m	M16*1.5.M	M16*1.5.F	375	182	375	159	375	49	80	0	55	2	11
ESDH370F static pressure: 35MPA, dynamic pressure: 22MPA							Dimensions are in millimeters										

